

DAB Schwimmbadpumpe 2"
Innengewinde 5.6A 230VAC
Schwarz Typ ESWIM 150 1,5PS
(7043227)



REBER
Bewässerungssysteme

TECHNISCHE DATEN

Farbe	Schwarz
Pumpengehäuse	verstärkt Technopolymer
Material Laufrad 1	verstärkt Technopolymer
Anschluss	Innengewinde
Spannung	230VAC
Max. Temperatur	40 °C
Herz	50 Hz
IP Wert	IPX5
Typ	ESWIM 150
Leistung	1.5 PS
Maß	2"
Länge	550 mm
Breite	300 mm
Gewicht	19 kg
Leistung	1.1 kW
Höhe	316 mm
Ampere	5.6 A



Max Durchfluss

30 m³/h

Packungsgröße L/B/H

720 x 350 x 430 mm

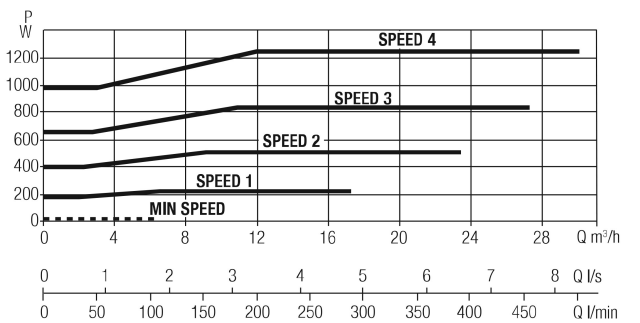
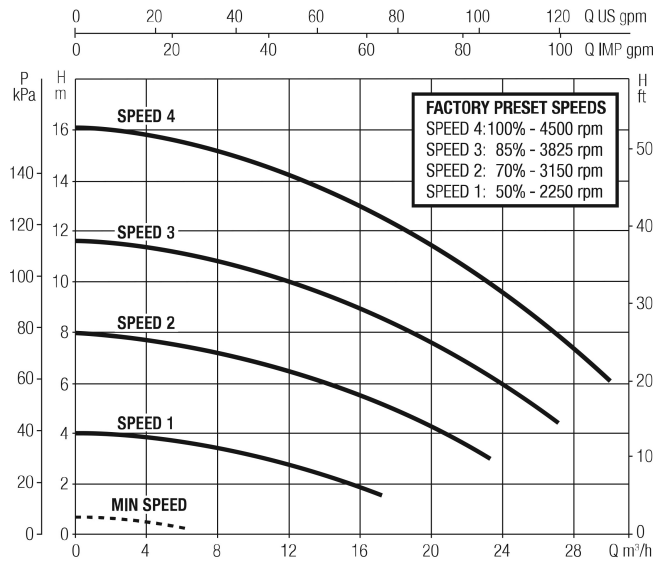
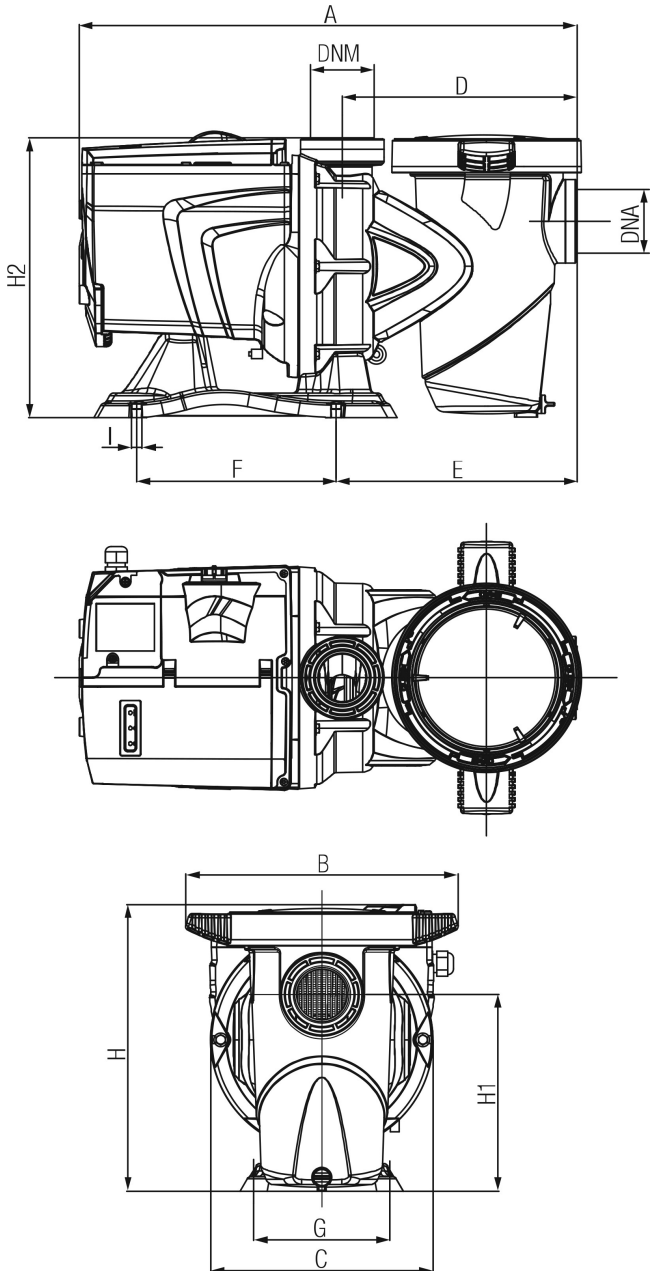

Generiert am: 14.03.2026



REBER
Bewässerungssysteme

Reber Beregnung GmbH
Gottlieb Daimler Str. 2
67227 Frankenthal
Deutschland
+49 (0) 6233 3772 - 0
info@reberberegnung.de
<http://www.reberberegnung.de>



REBER
Bewässerungssysteme